

VACUUM PUMP

UVP-5/11/21/34/45



Table of Contents

Thank you for purchasing our product. We know that in today's competitive marketplace, customers have many choices when purchasing laboratory equipment. We appreciate your choosing our quality product. We stand behind our products and want to let you know we are here if you need us. Before you use the unit, read this entire manual carefully to understand how to install, operate and maintain the unit in a safe manner. Your satisfaction with the unit will be maximized as you read this manual thoroughly. Our capable products will satisfy you by the best performance with easy operation.

1. Features & Specification	3
2. Basic Parts	5
3. Installation	6
4. Operation	7
5. Inspection & Maintenance	8
6. Troubleshooting	10
7. Warranty	11

01. Features & Specification

UVP-5/11//21/34/45

Perfect design and performance

Constantly pursuing on highest technology norms, The vacuum pump of USA LAB Inc reached new highest level: cylinder structure and innovative oil circulation system results in super stability; auto anti-suck back valve and two shifts gas ballast makes best reliability; Perfect combination of technology and aesthetics helps to become classic.



- Tow-Shift adjustable gas ballast valve satisfies different requirements of condensable vapor(such as water vapor) to be exhausted out of pump in different processes.
- Dual protection of oil anti-suck back ensures vacuum system from oil pollution when pump stops running and needs to be easily restarted.
- Forced oil circulation system consisted of oil pump and constant pressure oil supply mechanism ensures stable running of the pump.
- Less components are used, easy to maintain and repair.

Specifications

Model	UVP-5	UVP-11	UVP-21	UVP-34	UVP-45
Pumping Speed(60Hz)	5.5 cfm	11 cfm	21 cfm	34 cfm	45 cfm
Ultimate total pressure gas ballast close	5x10 ⁻² Pa (3.7x10 ⁻⁴ torr)	4x10 ⁻² Pa (3.0x10 ⁻² torr)	4x10 ⁻² Pa (3.0x10 ⁻² torr)	4x10 ⁻² Pa (3.0x10 ⁻² torr)	4x10 ⁻² Pa (3.0x10 ⁻² torr)
Ultimate total pressure gas ballast open	10 Pa (7.5x10 ⁻² torr)	8x10 ⁻¹ Pa (6x10 ⁻³ torr)	8x10 ⁻¹ Pa (6x10 ⁻³ torr)	8x10 ⁻¹ Pa (6x10 ⁻³ torr)	8x10 ⁻¹ Pa (6x10 ⁻³ torr)
Power supply	1 Phase (110V, 60Hz)				
Power rating(kW)	0.4	0.75	1.1	1.5	2.2
Inlet/Exhaust Flange	KF 25	KF 25	KF 25	KF 40	KF 40
Oil capacity(L)	0.6~1.0	0.9~1.5	1.3~2.0	3.3~4.5	3.3~4.5
Ambient temperature(°C)	10~40°C				
Noise level(dB)	≤56	≤60	≤60	≤62	≤62
Weight(kg)	21	30	43	62	65

01. Features & Specification

Flow Rate Characteristic

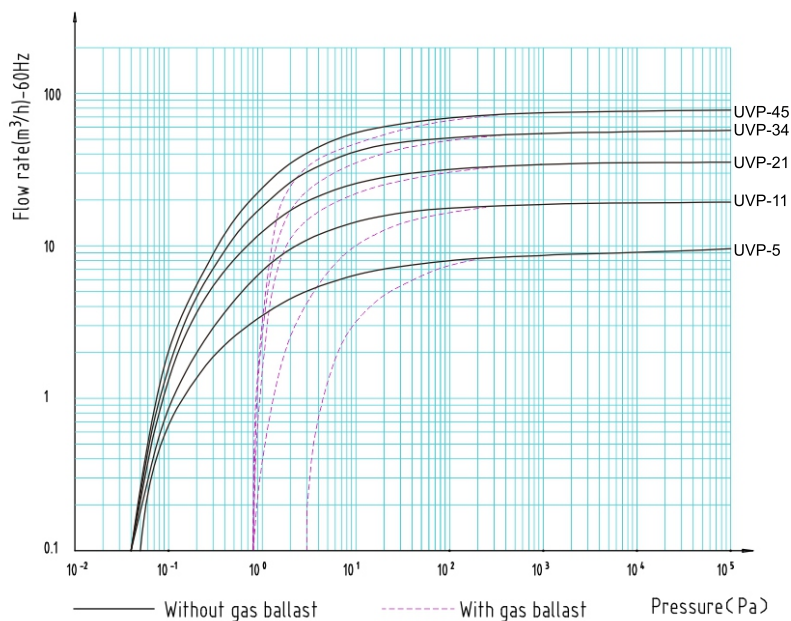

Dimension

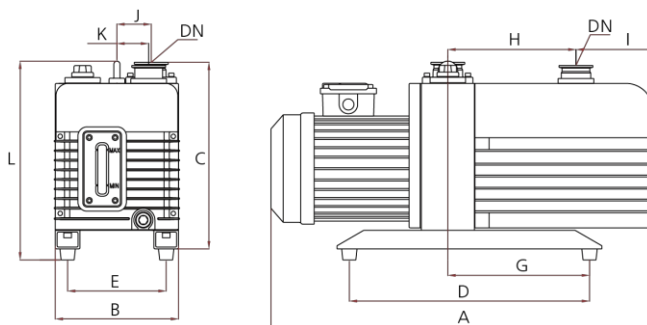

Dimensions

Model	A	B	C	D	E	G	H	I	J	K	L	DN
UVP-5	440	144	217	210	110	95	143.5	45	45	34	/	KF25
UVP-11	530	188	272	320	148	160	165	69	59	38	295	KF25
UVP-21	567	188	272	320	148	160	185	82	59	47	295	KF25
UVP-34	730	234	358	396	190	200	223	157	69	55	390	KF40
UVP-45	730	234	358	396	190	200	223	157	69	55	390	KF40

02. Basic Parts

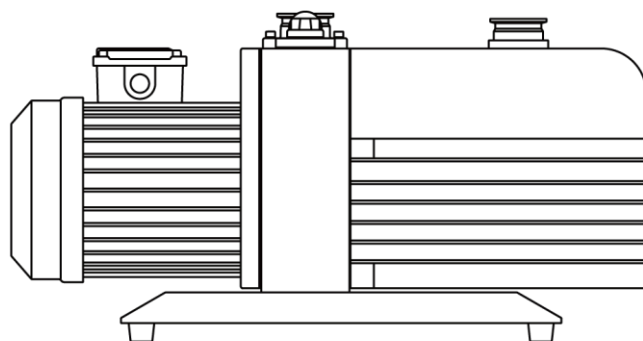

<Main unit>

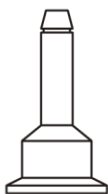

Hose barb : 1EA

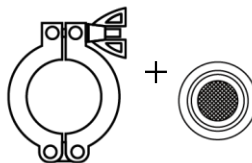

Clamp with O-ring: 2SETS



Oil

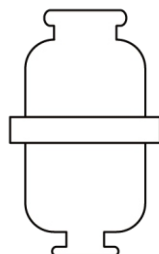

Oil Mist Trap

03. Installation

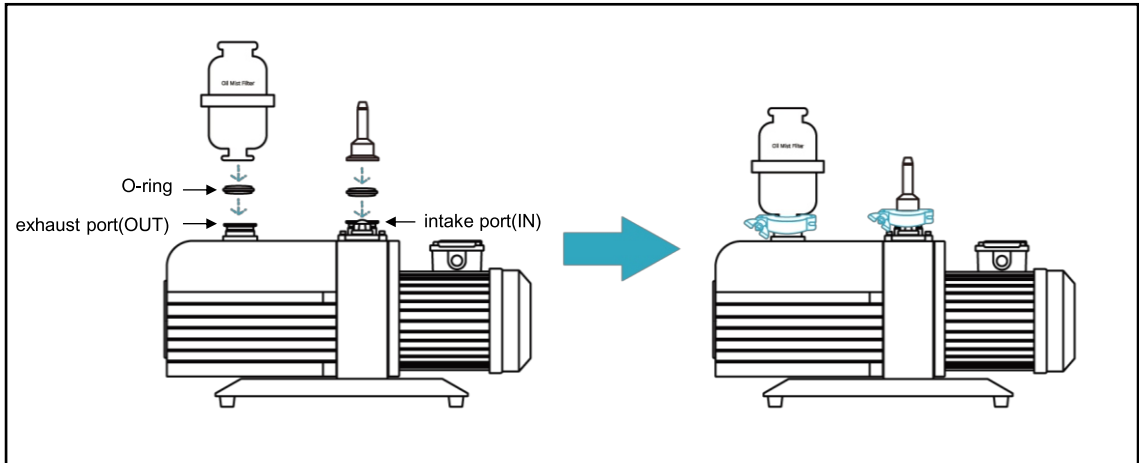

- ① Please put the O-ring between the intake port and the hose barb and tighten the clamp.
 (*In case of Oil Mist Trap, please install it in the exhaust port in same way.)

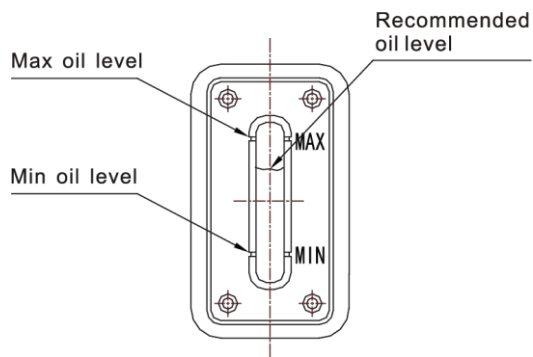

<Fig. 1>

- ② The oil level shall be kept between position MAX and MIN of oil sight glass. Excessive or insufficient oil will decrease the pump performance or even cause malfunction. The pump must be stopped before adding oil.

04. Operation

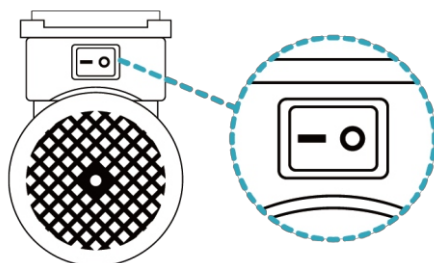

- ① Please plug-in the power cord 110V and switch on the pump.

Gas ballast
valve
knob arrow 

<Fig. 2> Gas Ballast Valve

- ② Please lock the gas ballast valve. (Set to the position C, Fig.2)

※ Pumping condensable gases and vapor

- 1) If the vacuum system contains a small amount of condensable gas, please open the gas ballast valve (set the gas ballast to position I or II, refer to Fig. 2) and warm-up the pump for 30 mins to pump the condensable gas effectively. Then, set the position of the gas ballast valve to C.
- 2) If the pump operates at low temperature, condensable gas may be dissolved in the pump oil and oil may be emulsified or deteriorated which will affect the pump performance, even cause corrosion of the pump body. So, 10 mins warm-up is recommended before ordinary operation.
- 3) If oil level raises during pump operation, it's a sign of condensable gas contained in the vacuum system. Do not switch off the pump immediately when the process is finished. Please follow the gas/vapor exhaust process as 1).



High temperature hazard! Do not touch the surface! The surface of the pump could be very hot during operation and after shutdown within one hour.



Make sure the gas flow at the exhaust port is not blocked or restricted in anyway. Do not start the pump if the exhaust port is blocked.



The operating ambient temperature is 10~40°C and humidity should be less than 85%.

05. Inspection and Maintenance



All checks and maintenance must be performed by trained personnel in accordance with local safety rules and regulations.



In case of presence of hazardous substances due to oil decomposition or media sucked into the pump, it's necessary to define the hazard and take all necessary safety precautions.



In the presence of hazardous substances, determine the hazard in the first time and follow all appropriate safety procedures. If the potential hazard still exists, the pump must be decontaminated before any maintenance.

5-1. Routine inspection

Content	Operation	Interval	Remarks
Oil level	Visual inspection	Every three days	5.2.1
Oil color	Visual inspection	Every three days	5.2.1
Pump noise	Acoustic inspection	Every three days	5.2.2
Pump vibration	Visual inspection	Every three days	Check the pump feet or feet bolts in case of abnormal vibration.
Pump temperature	Temperature meter	Every one week	Check and clean fan of the pump and motor for deposits.
Seal & O-ring	Visual inspection	Every one month	Replace it if necessary
Dirt trap	Visual inspection	Every one month	Check and clean the foreign matter. Dry it by compressed air.

05. Inspection and Maintenance

5-2. Maintenance

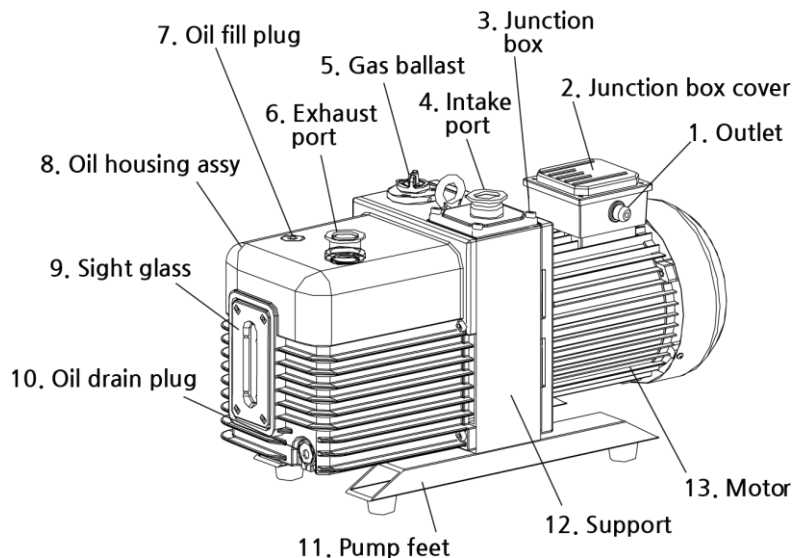

<Fig. 3> Outside view

• 5.2.1 Checking oil level

- 1) The oil level shall be always kept between position MAX and MIN of oil sight glass during operation(refer to Fig. 1). Add oil when the oil level is lower than position MIN and discharge oil by removing the drain plug (refer to Fig.3) when the oil level is above position MAX.
- 2) Check the oil color. Replace the oil if the color is other than clear and transparent.

• 5.2.2 Checking pump's noise

The pump noise shall be continuous and stable during operation. If any abnormal noise is found, please check troubleshooting.

• 5.2.3 Changing oil

- 1) Change the oil when the pump is switched off and cooled down.
- 2) Remove the oil drain plug(Fig.3) and drain the used oil into a suitable receptacle. When the flow of oil stops, screw on the oil drain plug and start the pump shortly(10 seconds). Switch off the pump, remove the plug again and drain the residual oil. Screw on the oil drain plug(Check O-ring, replace it if necessary). Remove the oil fill plug(Fig.3) and fill in fresh pump oil which is specified or provided by the manufacturer.
- 3) After oil changing, handle the used oil stored in an assigned container according to local relevant environmental laws and regulations.

• 5.2.4 Regularly checking intake filter and anti-suck back valve

Regularly take down the intake port and clean the filter by compressed air. Check the seal position of anti-suck back valve for cleanness, damage, hardening and height.

• 5.2.5 Regularly checking fan cover and motor fan

Regularly remove and clean the fan cover and motor fan. Clean them by compressed air and reinstall them properly before pump operation.

06. Troubleshooting

Fault	Possible reason	Remedy
Pump cannot start	Wiring is malfunctioning.	Check and repair wiring.
	Operation voltage is abnormal.	Make sure the voltage is within rated voltage's tolerance of $\pm 10\%$.
	Motor is malfunctioning.	Replace the motor.
	Overload protector is active.	Check the ambient temperature.
	Oil temperature is below 10°C.	Increase the ambient temperature.
	Pump is jammed.	Repair the pump.
	Out of operating for long.	Repair the pump.
	Oil is too viscous.	Change the oil.
	Exhaust filter or exhaust line is clogged.	Replace the filter or clean the exhaust line.
	Pump inner parts are damaged.	Repair the pump.
Pump cannot reach Ultimate pressure.	Vacuum system configuration is unreasonable.	Choose a suitable pump.
	Vacuum system leak.	Check the system.
	Measuring technique or gauge is unsuitable.	Use correct measuring technique and gauge. Measure the pressure directly at pump's intake port.
	Oil filter is obstructed.	Change the oil filter.
	Oil is unsuitable.	Change the oil.
	Oil channel is obstructed.	Clean the channel.
	Oil is insufficient.	Add the oil to the level as requested.
	Anti-suck back oil valve is malfunctioning.	Repair anti-suck back oil valve.
	Intake line is dirty.	Clean vacuum lines.
Pumping speed is too low.	Intake port line is clogged.	Clean the intake port line.
	Connecting lines are too narrow or too long.	Use adequately wide and short connecting lines.
	Exhaust line is clogged.	Keep exhaust port line unobstructed.
	Oil mist filter is clogged.	Change the oil mist filter.
	Anti-suck back oil valve is malfunctioning.	Repair anti-suck back oil valve.
Noise is abnormal	Operation voltage is abnormal.	Check the power supply, switches and wiring connection. Make sure the voltage is within rated voltage's tolerance of $\pm 10\%$
	Foreign matters entering into the pump.	Repair the pump.
	The oil level of the pump is too low.	Add the oil to the level as requested.
	The pump inner parts are damaged.	Disassembly and replace the parts.

06. Troubleshooting

Fault	Possible reason	Remedy
Pump gets hotter than usually observed.	Poor ventilation.	Improve ventilation environment.
	The fan is damaged.	Change the fan.
	Pumped gas temperature is too high.	Add cold trap at intake port.
	The oil filter or exhaust line is clogged.	Replace oil filter or clean the exhaust line.
	Oil is unsuitable.	Change the oil.
	Oil channel is obstructed.	Clean the channel.
	Oil is insufficient.	Add the oil to the level as requested.
	The condenser is dirty.	Clean the condenser.
	Ambient temperature is too high.	Reduce ambient temperature.
Oil in the intake line or in vacuum vessel.	Oil comes from the vacuum system.	Check the vacuum system.
	Anti-suck back valve spring is obstructed.	Replace anti-suck back valve spring.
	Anti-suck back valve plate is obstructed.	Replace anti-suck back valve plate.
Vacuum pressure in system rises too fast when pump stops.	Oil level is high.	Drain the excess oil.
	Vacuum system leak.	Check the system.
	Anti-suck back oil valve is malfunctioning.	Repair anti-suck back oil valve.
Too much oil in the exhaust port.	Too much oil in the pump.	Drain some oil.
	Continuous operation under high pressure in the intake port.	Shorten exhaust time.
	Oil mist filter is obstructed.	Replace oil mist filter.
Sealing surface leak	The seal is damaged.	Replace the seal.
	Seal ring is damaged.	Replace the seal ring.

07. Warranty

UVP series vacuum pump have one year guarantee from the date of purchase. Spare parts will be provided free of charge within the period of guarantee in condition that the pump is operated according to the operating manual. The following failures will be charged for repair:

- 1) Malfunction caused by nature disasters or artificial factors.
- 2) Malfunction caused by special operating environment.
- 3) Damage of wear parts.
- 4) Malfunction caused by abnormal operation or incorrect use indentified by our engineers.



11730 Globe St.
Livonia MI 48150
Call us at 734-855-4890